



**Cu-Built**

An ISO 9001 : 2008 Certified Co.

# CUBUILT

ENGINEERS PVT. LTD.



[www.cubuilt.com](http://www.cubuilt.com)









Cu Built Engineers Pvt Ltd is an ISO 9001: 2008 Certified Company incorporated in the year 1995. We are well known by our trade mark Custom Built.

We are pioneer in the field of Design, Manufacture, Supply and Erection & Commissioning of complete range of Welding Automation Systems.

Under the visionary guidance of our respected Managing Director, Mr. P. S. Patil, we have attained distinguished position in the market. His vast domain expertise as well as business acumen have supported us to enlarging our operations globally.

Our Standard Products range is as follows :

- ❑ Welding Column & Boom
- ❑ Welding Rotators
- ❑ Hydraulic Shell to Shell Fit-Up Rotators
- ❑ Welding Positioners
- ❑ Welding Turn Table
- ❑ Head Stock & Tail Stock Set Up
- ❑ Hydraulic Scissors Lift
- ❑ H / I Beam Welding Set Up
- ❑ PEB Welding Set Up
- ❑ Internal & External Overlay System
- ❑ Special Purpose Welding Automation Systems
- ❑ Material Handling Trolleys
- ❑ EOT / Goliath / Jib Cranes
- ❑ All Type of Structural Fabrication

The first year proved to be a testing time with all our valuable customers and the year ended with a modest turnover of Rs. 12 Lakh. Thereafter, there was no looking back. Quality products blended with perfect workmanship, an unmatched after sales service and with an urge for growth resulted in the Company crossing the Rs 50 Crore Annual Turnover. Over the years the domestic and overseas customers have been patronizing our products with repeat orders.

The Manufacturing Unit & Registered Office are located in Bhosari, Pune which is approximately 155 kms from Mumbai, the commercial capital of India. We have Experienced R&D Department and Modern Manufacturing Facilities to accomplish the exceeding needs of our customers with 280+ Experienced Employees and 5 Full Fledged Manufacturing Facilities in India

## Quality Policy

We are committed to deliver product in compliance to International Standards in Terms of Design, Manufacturing, Work Manship, Timely Delivery, Availability of Spares and After Sales Services at a Competitive Prices as per Customer Requirement.

We achieve our quality objectives through training and motivating the employees and continual improvement of our Quality Management System.

## Quality Objectives

- ❑ On Time Delivery to Customer
- ❑ Increase Customer Satisfaction Index
- ❑ Training to all Employees
- ❑ Maintain a fair and creative work environment
- ❑ Implementation of best practices and global processes
- ❑ Increase Sales Turn Over
- ❑ Increase Supplier Performance
- ❑ Increase QMS Performance



# WELDING ROTATORS



Welding Rotators are very essential equipments for heavy and light fabrication shop. They are mainly used to rotate or position the cylindrical jobs for circumferential welding (TIG / MIG / Sub Arc) or for intricate assemblies. The machine consists of 1 No. Drive Unit and 1 No. Idler Unit and Control panel with pendant. For step less speed variation, AC Variable Frequency Drive is used. The rollers are either made of Steel or Moulded with Polyurethane as per customer's requirement.

## Application

- ❑ Welding of Pipes
- ❑ Boilers
- ❑ Pressure Vessels / Tanks
- ❑ LPG Bullets
- ❑ API Pipes
- ❑ Heat exchangers
- ❑ Mounted vessels
- ❑ Barrels, etc.

## Advantages

- ❑ An indispensable tool for shell fabrication shops.
- ❑ Attains exceptional quality circumferential joints on shells.
- ❑ Increased production with reduced labour.
- ❑ Leads to minimum handling of the Shell / Job.
- ❑ Lesser usage of crane thereby reduces idle time.
- ❑ Adaptable for automatic or manual welding.

## There are three Design Variants in Modern Rotators

### 1. The Conventional Type : Model 'CUCR' -Type

Main base frames are fabricated and stress relieved before machining. There are basically two units, the Drive and Idler - one unit each. The precisely machined (on boring machine) Roller Brackets are bolted on the roller beds. Both the Roller Brackets have to be manually moved as per the job diameter keeping the center fixed. This model has double ended drive to avoid use of diameter setting drive shaft. The fixing holes for the brackets on the bed are precisely factory set.

#### Salient Features

- ❑ Low investment cost.
- ❑ Ideal version to start with new fabrication line.
- ❑ Most suitable for small and heavy fabrication shops.
- ❑ Simple & Sturdy design.
- ❑ Proven reliability.
- ❑ Accepts wide range of Job diameters.





## 2. Self Centering Type: Model 'CUSR' -Type

The construction of this type is similar to Conventional Type except that this model has a provision to slide the Roller Brackets over the Base Frame equally in both directions through a lead screw having LH & RH Threads.

Unlike in Conventional Type the Roller Brackets in Self Centering Type is not bolted on the base frame. The rotation of lead screw can either be Manual or Motorized (Optional). The Technical Specifications are same as Conventional Type.

### Salient Features

- ❑ Low investment cost.
- ❑ Ideal version to start with new fabrication line.
- ❑ Most suitable for small and heavy fabrication shops.
- ❑ Simple & Sturdy design.
- ❑ Proven reliability.
- ❑ Accepts wide range of Job diameters.



### 3. The Self Aligning Types :- Model 'CUSAR' -Type

Self Aligning Rotators automatically adjust the Roller Housings to accept any job diameters within the specified diameter range. These types of machines are generally used to cope with the increased production demands. The roller housings of this type of machine are hinged to the beds and open up automatically when a larger diameter job is introduced. In this type of rotator, each Roller bracket assembly has two separate roller assemblies, and this supports the job on a wider area. The final drive is given to all the 4-sets of rollers of the Drive Unit in special models, providing better traction to the job. However, in that case a de-clutching arrangement is provided to the top rollers, in order to protect the gear boxes, as when the job hits the top rollers first while loading, forcing it to rotate via. the self locking gear box.

#### Salient Features

- ❑ Both the rollers automatically get adjusted for all job diameters.
- ❑ Accepts complete range of job diameters in one setting.
- ❑ Center axis of job remain stable for all job diameters.
- ❑ Wide range of Job diameters and Load capacities.
- ❑ Most suitable for 'thin walled' shells of large diameters.
- ❑ 'Four roller' contacts gives superior 'slip free' traction for thin walled vessels.
- ❑ Proven reliability and higher productivity.
- ❑ Most accepted design for very busy fabrication shops.
- ❑ Ideal design for using in conjunction with Column & Boom.
- ❑ Better acceptability to ovality of vessels compared to other models.

#### Standard capacity ranges

Load carrying capacity - 5 Ton to 1000 Ton

Job diameter Ranges - 1200mm to 10000 mm (Higher diameters on request)





## 4. Hydraulic Shell to Shell Fit-Up Rotators Model 'CUFIT' Type

Cu-Built Hydraulic Shell to Shell Fit-Up Rotators are specially designed to Align, Rotate and Support two sections of same diameter Shells for 'Tack Welding' or 'Full Circumferential Seam Welding'. Different diameters of cylindrical jobs can be accommodated on them as per the design for which it is intended. Fit Up Rotators are Used for assembly or Fit-Up of Long Pipe / Tanks / Wind Tower / Vessel, etc.

Fit Up Rotators have Four Units, Two Units (1No. Drive Unit + 1No. Idler Unit) are with Trolley Wheels and the other Two are Hydraulic Fit Up Units Fixed Base Type. Trolley of Drive Unit has inbuilt drive system, so that the shell section supported on them can be moved forward or backward, in order to butt the shell edge, against the edge of the other shell on the fixed units.

If different length of shells are involved, it is better to have these of the units on Trolley wheels, and only one unit fixed. This will help to easily adjust the distance between the shell supporting units to the length of the shell sections.



# WELDING COLUMN & BOOM



Welding Column & Boom is also called as Welding Head Manipulator. The welding head is mounted at one end of the Boom. The wire spool can be mounted at the front or at the rear end of the Boom. In Extra Light Duty and Light Duty Models (i.e. up to 3 meter X 3 meter), the vertical movement is through Lead Screw. And for Medium & Heavy Duty Boom, the vertical movement is through Rack & Pinion with counter weight arrangement. The Counter weight and Boom assembly is firmly held with metallic wire rope. Provision of anti-fall security is a standard feature in all models including Lead Screw driven ones. The Horizontal Boom drive movement is through rack and pinion for all models of Column & Boom

## Application

- ❑ Welding of Pipes
- ❑ Boilers
- ❑ Pressure Vessels / Tanks
- ❑ LPG Bullets
- ❑ API Pipes
- ❑ Heat exchangers
- ❑ Mounted vessels
- ❑ Barrels, etc.

## Advantages

- ❑ Increased Production.
- ❑ Allows maximum flexibility to welding head manipulation.
- ❑ Better weld quality with reduced labor.
- ❑ Dependable even for most critical weld quality.
- ❑ Assured high quality welding non-dependent on operator's skill.
- ❑ Essential tool for automatic / semi-automatic welding.
- ❑ Ensures 360° radial accessibility to welding head, covering vast area in the shop.
- ❑ Trolley car mounted version gives accessibility to the full shop length.
- ❑ Easy high quality automatic circumferential or longitudinal seam welding in conjunction with Rotator or Positioner.
- ❑ Indispensable for pipe / vessel fabrication shops.





## Salient Features

- ❑ Rugged Construction.
- ❑ Wide Base & Lockable 'Swivel Base' to enhance Stability.
- ❑ Minimum Deflection even when 'Boom' extended fully.
- ❑ Precise 'Jerk free' vertical & horizontal movements.
- ❑ Over rated, pre-loaded and dust protected bearing arrangements.
- ❑ Operator's seat at conveniently placed location. (Optional)
- ❑ Option for self propelled Chair for operator on heavy duty models.
- ❑ Option for walkway along the boom.
- ❑ Option for Drag Chain for cable/pipe movement along the Vertical & Horizontal plane.

## 1. Small Duty Models (Light Duty Type) - 'CCBL' Models.

Available Range: Up to 3.5 meter Vertical Stroke X 3.5 meter Horizontal Stroke.

### Features

- ❑ Most Economical Design.
- ❑ Proven Reliability.
- ❑ Very Low Investment cost.
- ❑ Most suitable for low budget fabrication & small vessel shops.
- ❑ Can perform wide range of applications.
- ❑ Safety ensured design (in case of L.S. Nut wear out, operator's safety is assured by auto-engagement of 'Anti-fall Nut'.)
- ❑ Lead Screw-Nut drive for UP / DOWN movement of Boom

### Standard Ranges

Minimum Vertical Stroke – 1000 mm & Minimum Horizontal Stroke – 1000mm  
Maximum Vertical Stroke – 3500 mm & Maximum Horizontal Stroke – 3500 mm  
Options: CCBL(P) Models (P - Pedestal Mounted Base) & CCBL(T)  
Models (T-Trolley Car Mounted Base).



## 2. Medium Duty Models - 'CCBM' Models.

Available Range: Above 3.5 meter Vertical Stroke X 3.5 meter Horizontal Stroke.  
Up to Maximum 6 meter Vertical Stroke X 6.5 meter Horizontal Stroke

### Features

- ❑ Robust Design.
- ❑ Proven Reliability
- ❑ Reasonable Investment cost
- ❑ Most suitable for Medium Fabrication & Vessel Shops.
- ❑ Can perform wide range of applications.
- ❑ Smooth Rack & Pinion Drive for both Up/Down & Horizontal Movement of Boom.
- ❑ Anti-toppling device for Trolley car mounted versions.

### Standard Ranges

Minimum Vertical Stroke – 3500 mm & Minimum Horizontal Stroke - 3500 mm  
Maximum Vertical Stroke – 6000 mm & Maximum Horizontal Stroke - 6500 mm

### Options

CCBM(P) Models (P - Pedestal Mounted Base) & CCBM(T) Models  
(T - Trolley Car Mounted Base).





### 3. Heavy Duty Models - 'CCBH' Models

Available Range: Above 6 meter Vertical Stroke X 7 meter Horizontal Stroke.  
Up to Maximum 7.5 meter Vertical Stroke X 8 meter Horizontal Stroke

#### Features

- ❑ Most Favoured Design
- ❑ Proven Reliability and High Stability.
- ❑ Ideal for large Fabrication Shops.
- ❑ Most suitable for large Vessel Shops.
- ❑ Can perform wide range of applications.
- ❑ Smooth Rack & Pinion drive for both UP / DOWN and Horizontal movements.
- ❑ Over rated wire rope to hold counter balancing weight of the Up/Down drive.
- ❑ Anti-toppling device for Trolley car mounted versions.

#### Standard Ranges

Minimum Vertical Stroke – 6000 mm & Minimum Horizontal Stroke - 7000 mm  
Maximum Vertical Stroke – 7500 mm & Maximum Horizontal Stroke - 8000 mm

#### Options

CCBH(P) Models (P - Pedestal Mounted Base) & CCBH(T) Models (T - Trolley Car Mounted Base).

### 4. Extra Heavy Duty Models - 'CCBEH' Models

Available Range: Above 7.5 meter Vertical Stroke X 8 meter Horizontal Stroke.  
Up to Maximum 10 meter Vertical Stroke X 10 meter Horizontal Stroke

#### Features

- ❑ Rugged Design
- ❑ Proven Reliability and High Stability.
- ❑ Ideal for very large Fabrication Shops.
- ❑ Most suitable for extra large Vessel Shops.
- ❑ Can perform wide range of applications.
- ❑ Smooth Rack & Pinion drive for both Up / Down and Horizontal movements.
- ❑ Over Rated wire rope to hold counter balancing weight of the Up/Down drive.
- ❑ Anti-toppling device for Trolley car mounted versions.

# WELDING POSITIONERS

Positioners are mainly used to manipulate and position the Jobs for 1G position for easy down hand welding, independent of operator's skill. Once the job is loaded it can be manipulated conveniently to complete all the welding operations in down hand position. This reduces handling time and frequent use of crane. The job can be tilted from 0° to 135° depending on the requirement of specific location of welding. Positioners can be conveniently used for complete circumferential welding, strip cladding, for down hand position welding, to set the job conveniently for easy accessibility to intricate assemblies etc. Along with Column & Boom, a positioner can carry out any welding tasks which are impossible otherwise.



## Special Features of our Design

- ❑ Extremely Stable and 'Free Standing' with the maximum rated load.
- ❑ 'Free standing' design allows frequent change of site.
- ❑ Rugged and robust Design / Construction.
- ❑ Generous 'Rotational' and 'Tilt' torque.
- ❑ Enhanced 'CG' rating due to specific design, lowering the distance to the 'Pivot point' from table top.
- ❑ Over rated, Pre-loaded and dust protected bearing arrangements.
- ❑ Forced diversion of 'Earth return current' off the spindle bearings, averts bearing damage.
- ❑ Activation of mechanical 'Stoppers' in case of limit switch failure.



## Standard capacity ranges

- Load capacity - 25 Kg to 200 Ton  
Table Rotation - A.C. Variable Speed OR A.C Fixed Speed (As per Customer Requirement)  
Table Tilt range - 0 to 135° OR -45° to +90° (AC Fixed Speed)

## Optional Features

- ❑ Degree of tilting angle can also be - 45 to +90 degrees to the horizontal.
- ❑ In case face plate diameters are required more than the standard versions, please specify for such requirements. Also mention, whether extension arms are required to accommodate increased diameter.
- ❑ Machined "T" slots at extra cost. Please specify for such requirements in your enquiry.
- ❑ AC VFD for tilt drive.

## Other Options

- ❑ Head Stock - Tail Stock Set Up
- ❑ Elevating Type Positioners (Adjustable Table Height)
- ❑ Turn Tables (Horizontal (i.e. 0° Fixed) or Vertical (i.e. 90° Fixed) Tables)



# WELDING SPECIAL PURPOSE MACHINE



We design and manufacture any Special Purpose machine for Automatic/ Semi-automatic/Manual Welding. These SPMs may use any welding process as required for the specific job. The welding process may be MIG / MAG, TIG, or SAW. Some of the SPMs we have manufactured for various customers are as follows:

## Sailent Features

- ❑ Manufacture as per Client requirement .
- ❑ Fully automatic / semi automatic reduces lead time of production.
- ❑ Can assure better quality of production.





## A convincing service in all respects

- ❑ Advice in planning stage.
- ❑ Complete design with modernized technology.
- ❑ Over rated, Pre-loaded and dust protected bearing arrangements.
- ❑ Personal Training.
- ❑ Upgrading and modernization.

### We can supply SPM's for applications such as:

- ❑ Automobile components.
- ❑ Accessories for TWO/FOUR wheeler vehicles.
- ❑ Road Rollers or any other similar cylindrical components.
- ❑ Hydraulic cylinders.
- ❑ Pipe to Flange welding.
- ❑ Turntable with TIG/MIG Torch mtq . arrangement with auto welding sequences.
- ❑ Complete LPG cylinder project including system handling.
- ❑ Domestic Pipes / API pipes welding equipment with automatic handling system.
- ❑ Automobile components of special nature.
- ❑ Special Accessories for TWO/FOUR wheeler components.
- ❑ Automatic loading and unloading systems for conveyor Idler Roller welding.
- ❑ Rebuilding setup for Road Rollers or any other similar cylindrical component.



# HYDRAULIC SCISSOR LIFT

Hydraulic Scissors Lifting Table is mostly used for Lifting Point of View. Our Designed Hydraulic Scissors Lifts can be Pit Installed or Floor Mounted for Indoor or Outdoor Use. We are in the field of Design, Manufacturing, Supply and Erection and Commissioning of Hydraulic Scissors Lifting Table based on the Customers requirement and their Application.

## Application

- Maintenance In Industrial Sector / Power Stations
- Loading / Un Loading of Material
- Maintenance In Railways / Air Port
- Packing of Material

## Salient Features

- Rugged Construction
- Flexible
- Compact Design
- Electric Full - Perimeter Toe Guard around the Platform
- High Performance
- Compact Hydraulic Power Pack





## Standard capacity ranges

- ❑ Load Carrying Capacity – 50 Kg to 5000 Kg
- ❑ Height of Lift – 500 mm to 15000 mm
- ❑ Movement – Manual / Motorized

## Standard Options

- Foot Operated Control
- Pallet Truck Approach Ramp
- Pendant / Remote
- Electrically / Battery Operated



# BEAM WELDING LINE

We offer a complete and efficient way of welding tailor-made beams and profiles. The lines are designed with economy and accuracy in mind, and can be delivered with additional equipment to suit special requirements for capacity and quality:



- ❑ Welding of I/H-beams, T-beams or L-beams, wide flange beams, columns & Tapered beams
- ❑ Integrated handling equipment for mounting and handling of webs and flanges, as well as handling of ready welded profiles

## Application

PEB, Petrochemical, heavy machinery, ship, structural steel construction and pressure container industry

## Salient Features

- ❑ Flexibility
- ❑ High production capacity
- ❑ Perfect Weld Quality
- ❑ Less space required
- ❑ Flange straightening not required after welding
- ❑ Few workers required





# INDUSTRIAL CRANES

We are engaged in the Design, Manufacturing, Supply and Erection & Commissioning of Industrial Cranes. Each product is made under the compliance of IS 3177 and IS 807. For special purpose cranes, like Steel duty cranes, IS 4137 Standard is followed. These standards verify and confirm the quality and safety of the products. & the raw material is used as per IS 2062. Our Product Range in Cranes and Material Handling Equipments is as follows

- Single Girder EOT Cranes
- Double Girder EOT Cranes
- Goliath Cranes
- Semi Goliath Cranes
- Jib Cranes
- Single Girder Hoists
- Double Girder Trolley (Crab)
- Industrial Transfer Trolleys
- Special Purpose Material Handling Systems

- Our cranes are manufactured maintaining high quality & latest safety norms with best workmanship.
- We are having most modern design facility with simulation features.
- Our experts team in crane design always give performance to user friendly design with priority in easy maintenance.
- We have adopted a modular production system to give faster delivery.
- Our cranes features are open and can be compared with any other crane manufacturer technically and commercially.
- We score higher on manufacturer selection parameter, due to our in-house facilities.
- We always ensure availability of inventory for emergency maintenance and assure interchangeability.

## PRODUCT SILENT FEATURES

- Modular Design
- Light in Weight
- Noise Free
- Hardened and Ground Gear Box
- Fully Machined and Self Lubricated End Trucks
- Power Saving
- VFD providing smooth and Jerk less Transition with required speeds
- Optimized and Compact Design to provide More Working Space
- Low and Easy Maintenance
- Over Load (Weight) Tripping Facility (Optional)

## EOT Cranes

We specialize in providing EOT Cranes that are compact in design and light in weight. EOT stands for electric overhead traveling cranes are fabricated using premium quality raw material.

### Single Girder EOT Cranes

We specialize in providing Single Girder EOT Cranes that are compact in design and light in weight. Manufactured using quality components, these are appreciated for their easy operation, long service life and low maintenance. Our range of Single Girder EOT Cranes issued for various construction purposes and is in great demand due to its following attributes:

#### Single Girder EOT crane

- ❑ Capacity 1 Ton to 20 Ton
- ❑ Available in: German Gear Drive with variable speed
- ❑ Span & Height of lift: Customized (As per requirement)



### Double Girder EOT Cranes

These are considered ideal for lifting and conveying loads of more than 10T and for span of over 25m. These are fabricated using quality-tested components and are provided with two torsion free box girders. Double Girder EOT Cranes offered by us are known for their high performance, excellent heavy load lifting capability and wide spans.

#### Double Girder EOT crane

- ❑ Capacity 5 Ton to 200 Ton
- ❑ Available in: German / Conventional Gear Drive with variable speed
- ❑ Span & Height of lift: Customised (As per requirement)





## Electric Wire Rope Hoists (Modular)

We hold expertise in providing Rope Hoists that are used for up, down, right and left movement of loads. We are leading manufacturers and suppliers of a wide range of Wire Rope Hoists, manufactured using quality approved basic material and cutting edge technology.

We are engaged in offering a comprehensive range of Electric Wire Rope Hoists (Modular). It is manufactured using quality material and is provided with fix suspension, geared trolley and power trolley. Our range of Electric Wire Rope Hoist is appreciated for its optimum quality, durability, trouble free performance and sturdy design.

### Electric wire rope hoist

- ❑ Capacity 1 Ton to 20 Ton
- ❑ Available in: German Gear Drive with variable speed
- ❑ Height of lift: Customised (As per requirement)

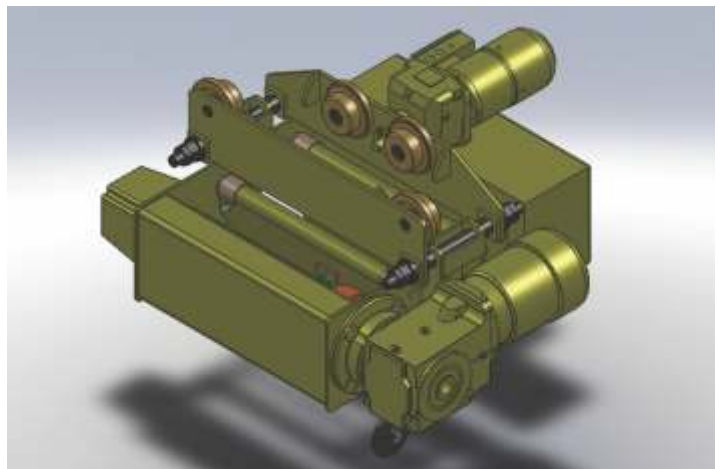

## Double Girder Trolley (Crab)

We hold expertise in providing Double Girder Trolley that are used for up, down, right and left movement of loads more than 10 Ton. Double Girder Trolley (Crab) is specially used for lifting & tilting heavy & big jobs.

It is manufactured using quality material and is provided with fix suspension, geared trolley and power trolley. Our range of Electric Double Girder Trolley (Crab) is appreciated for its optimum quality, durability, trouble free performance and sturdy design.

### Electric wire rope hoist

- ❑ Capacity 5 Ton to 200 Ton
- ❑ Available in: German / Conventional Gear Drive with variable speed
- ❑ Height of lift: Customized (As per requirement)

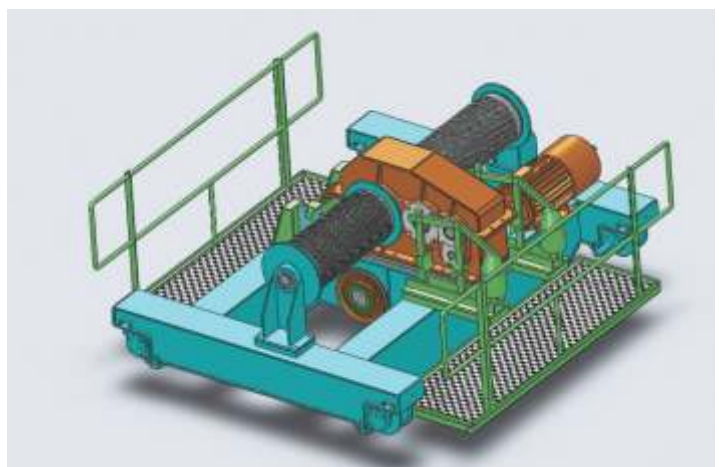

## Goliath Cranes

We are engaged in offering goliath cranes and gantry crane is extensively used in construction industry, shipping yards, roadsides, mines, quarries and many others. We hold in-depth expertise in offering Goliath (Gantry) Cranes that are appreciated for their low maintenance and high cost efficiency. Based on the latest technology, these are integrated with proper safety features and are appropriate for heavy load applications. Our range of Goliath (Gantry) / Semi Goliath Cranes is extensively used in construction industry, shipping yards, road sides, mines, quarries and many other.

### Types of Goliath Cranes

- ❑ Single Girder Goliath Cranes
- ❑ Double Girder Goliath Cranes

#### Goliath crane

- ❑ Capacity 1 Ton to 200 Ton
- ❑ Available in: German / Conventional Gear Drive with variable speed
- ❑ Span & Height of lift: Customized (As per requirement)





## Semi Goliath Cranes

In workshops where part utilization of shop bay is required (as in a tool room attached to a press shop), a Semi-Goliath/Gantry Crane is used. In such a configuration, one end-carriage of the crane will travel on the regular gantry rail while the opposite end-carriage will travel on a rail mounted typically on the ground or at a lower elevation.

Goliath / Gantry Cranes are self-propelled cranes running on rails installed at ground level. Such cranes are typically used at-

- ❑ Construction sites
- ❑ Workshops where existing columns cannot bear the wheel loads of a bridge crane
- ❑ Locations where bay lengths are excessive
- ❑ Locations where bay lengths do not remain constant
- ❑ Locations where loads are to be shifted from points outside the crane span as in the case of an over hang on either side of the rails
- ❑ Precise control of the up/down motion and / or travel motion can be achieved by fitting Variable Frequency Drives in the panels. Control can be either through a Pendant Push Button station or a Radio Remote Control (optional).

### Types of Semi-Goliath Cranes

- ❑ Single Girder Semi Goliath Cranes
- ❑ Double Girder Semi Goliath Cranes



## JIB Cranes

Jib cranes consist of a rotating arm with a hoist that runs along its length. The arm usually revolves on an axis which can be a fixed, ground-mounted post, or can be a wall or ceiling-mounted pin. Wall bracket mounted jib cranes are usually the least expensive jib cranes, but they require the most headroom and exert more force on their mounting wall. Cantilever jib cranes place the arm at the top, allowing for maximum lift when used in situations with limited headroom. They also exert less force on the wall on which they're mounted. Jib lifts are sold that slip onto the forks of a forklift, turning it into a mobile crane. More inexpensive jib cranes feature manually operated chain hoists, while more sophisticated cranes use an electric chain hoist. Optional jib crane features are available depending on the model and manufacturer, including portability, telescoping arms, articulating arms, motorized rotation, motorized trolley movement etc.

### Jib crane

- ❑ Capacity 1 Ton to 10 Ton
- ❑ Arm Length: Upto 10 mtrs
- ❑ Swivel: Upto 360 Degree



## Material Transfer Systems

Available with four and multiple wheels, our range of Motorized Transfer Trolley have capacity ranging from 1 ton up to 320 ton. Under the supervision of our professionals, the range is precisely manufactured using high grade raw material and advanced machines. Further, the range is stringently checked and tested before delivery so that our clients receive defect free products.

### Specifications

- ❑ Drive with motor, gear box
- ❑ Control with pendant or remote control
- ❑ A.C. frequency drives
- ❑ Power supply to trolley through cable reeling drum / shrouded DSL

## Types of Material Transfer Systems

❑ Industrial Transfer Trolley

❑ Special Purpose Material Transfer System

### Material Transfer Systems

- ❑ Capacity 1 Ton to 320 Ton
- ❑ Available in: German Gear Drive with variable speed
- ❑ Length & width of trolley: Customized (As per requirement)

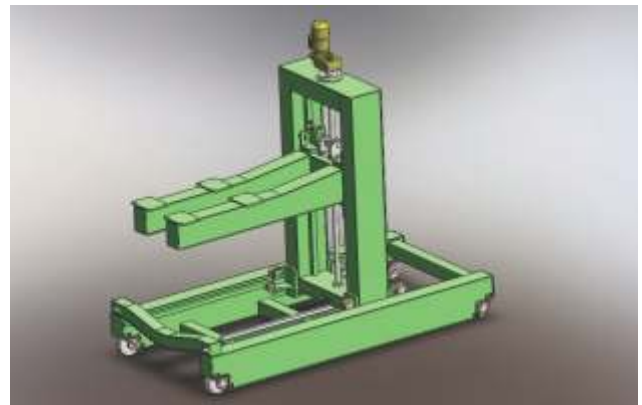

## Wall Traveling Cranes

Wall traveling cranes are in such a configuration, one side end carriages of the crane will travel and other end will be hanging like jib cranes and will move along the bay length through rails.

### Specifications

- ❑ Capacity 1Ton to 10Ton.
- ❑ Arm length up to 10Mtr.
- ❑ Available in German Geared Drive with variable speeds.
- ❑ Height of lift. Customized (as per requirement).

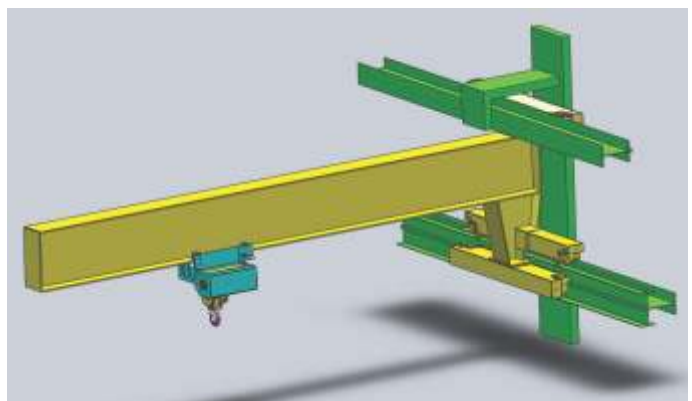



# OUR VALUED CUSTOMERS

## Domestic Base Customer



## Exports Base Customer



## CONTACT US



### Head Office:

Cu Built Engineers Pvt. Ltd.  
Plot No 149, Sector No 10, PCNTDA, MIDC, Bhosari, Pune – 411026  
Tel: +91 20 46763310, 46763991  
Fax: +91 20 46765128  
Email: sales@cubuilt.com, cubuilt@hotmail.com

### Manufacturing Unit 1

Cu Built Engineers Pvt. Ltd.  
Sector No 10, PCNTDA,  
MIDC, Bhosari, Pune – 411026  
Maharashtra, India

### Manufacturing Unit 2

Cu Built Engineers Pvt. Ltd.  
J – 513 / 1 / 2 MIDC,  
Bhosari, Pune – 411026  
Maharashtra, India

### Manufacturing Unit 3

Cu Built Engineers Pvt. Ltd.  
Gat No. 62 & 63, Village Ahire,  
Tal. Pargaon Khandala,  
Satara – 412802  
Maharashtra, India









An ISO 9001 : 2008 Certified Co.

# CUBUILT

ENGINEERS PVT. LTD.

🏠 Cu-Built Engineers Pvt. Ltd., Plot No. 149, Sector No. 10, PCNTDA, Bhosari, Pune - 411026  
☎ +91 - 20 - 46763310 / 46763991 📠 +91 - 20 - 46765128  
📠 +91 - 9823054103 / +91 - 9730089705  
✉ sales@cubuilt.com / cubuilt@hotmail.com  
🌐 www.cubuilt.com / www.cubuilt.in